

Product Datasheet

Quick Ship Emergency Tank Shower - 1200L (317 US Gallons)

QS1200

Freeze protected emergency tank shower for use in non-hazardous environments. Designed to provide tepid water for over 13 minutes at a guaranteed flow of 20 US gallons (76 liters) per minute, even when there is no plumbed in water supply. Features internally mounted, covered eye/face wash unit and rectangular hollow section stainless steel frames designed and built to be earthquake proof, conforming to the California Building Code. Ready for quick delivery—packed for economical shipment and assembly on-site.

Note: This tank shower is ANSI compliant for the 15 minute time requirement only when connected to a plumbed water source.



Specifications

MATERIALS OF CONSTRUCTION	
SHOWER ROSE	GRP and stainless steel
PIPING & VALVE MATERIALS	uPVC and stainless steel
CONTROL VALVE - SHOWER	uPVC 1½ in ball valve
CONTROL VALVE - EYE/FACE WASH	½ in 316L stainless steel full flow ball valve with stainless steel ball
EYE/FACE WASH STRAINER	½ in stainless steel
OVERFLOW	1 in NPT uPVC
BALLCOCK VALVE	2 x ½ in NPT brass
SHOWER VALVE LEVERS	Red reinforced nylon 6
EYE/FACE WASH VALVE LEVERS	Stainless steel
WATER TANK	1200 liter (317 US gallons) capacity medium density polyethylene HDPE
TANK SURROUND AND LID	Heavy-duty GRP in white
SHOWER FRAME AND LEGS	Stainless steel
PULL RODS FOR VALVE ACTIVATION	Stainless steel
ALL FASTENERS AND FIXINGS	Stainless steel
TECHNICAL DATA	
INLET CONNECTION SIZE & TYPE	¾ in NPT Female (interior), 2 in NPT Female (exterior)
SHOWER OPERATION	Panic bar
EYE/FACE WASH OPERATION	Lift lid
SUPPLY PRESSURE	8 to 145 PSI (0.5 to 10 BAR G)
FLOW AT OPERATING PRESSURE	Shower - 76 liters/minute (20 US gallons). Eye/Face wash - 12 liters/minute (3 US gallons)
ELECTRICAL EQUIPMENT - Non-hazardous	Suitable for use in areas classified as non-hazardous
HEATING LOAD	1.7kW
ELECTRICAL SUPPLY	110V, single phase, 50/60Hz
AMBIENT OPERATING TEMPERATURE	
MINIMUM	-10C / -14F
MAXIMUM	40C / 104F
DIMENSIONS & WEIGHT	
DIMENSIONS	1647 mm (64.8 in) x 1461 mm (57.5 in) x 3567 mm (140.4 in)
WEIGHT	Empty: 340 kg (750 lbs) Full 1534 kg (3382 lbs)

General Arrangement Drawing

Quick Ship Emergency Tank Shower - 1200L (317 US Gallons)

QS1200

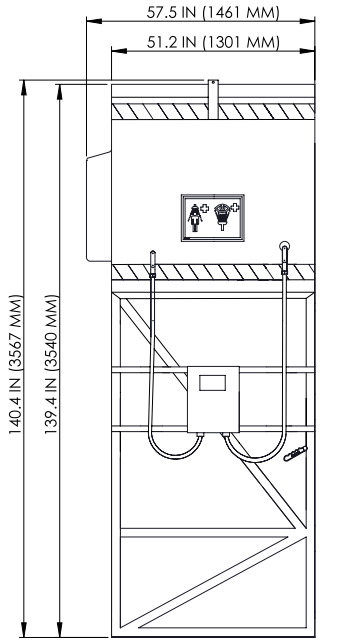

SIDE VIEW (EYEWASH OMITTED)

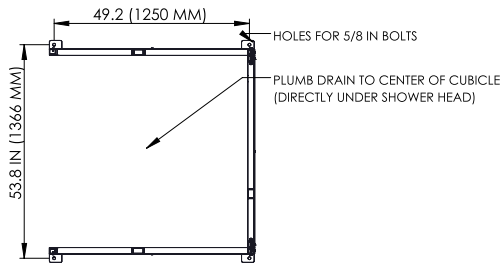
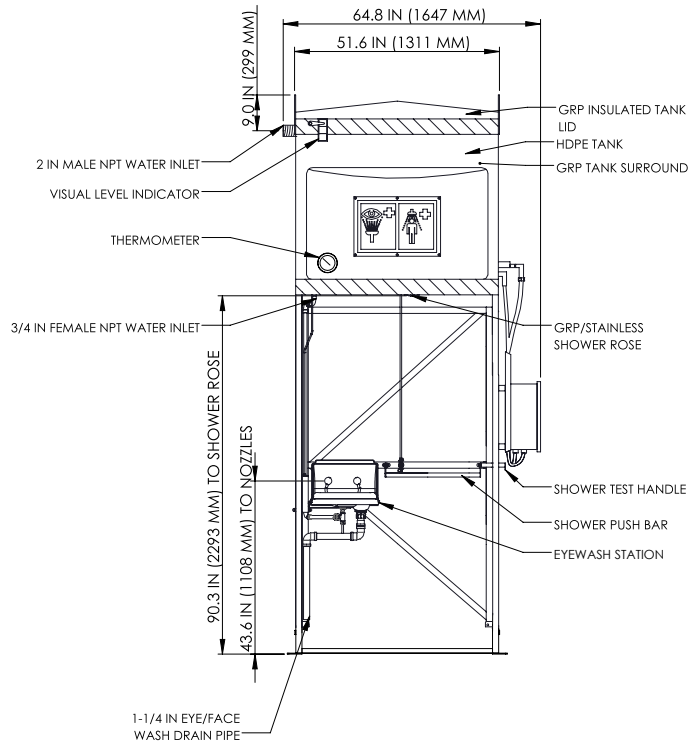

PLAN VIEW DETAILING FOOTPRINT

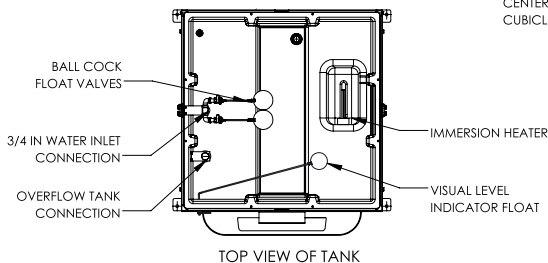

TOP VIEW OF TANK

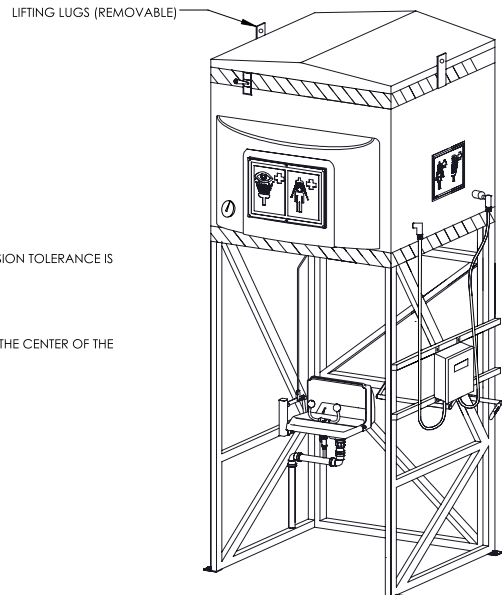

NOTES

DUE TO WELDING TOLERANCES, DIMENSION TOLERANCE IS +/- 0.4 IN (10MM).

TANK VOLUME TO 70.6 FT³ (2M³).

CENTER OF GRAVITY IS LOCATED NEAR THE CENTER OF THE CUBICLE, JUST BELOW THE CEILING.

HUGHES



HUGHES-SAFETY.COM

Justrite Safety Group

www.hughes-safety.com

Hughes Safety Showers Ltd, 457 Campbell Street, Sarnia, Ontario N7T 2J1 Canada
T: 1-866-312-1652 E: customer.service@hughes-safety.com